



Community Development
Department

DECKS

Permit Procedure:

All of the items listed below must be submitted to complete the permit review:

1. Submit a completed permit application (*IRC-R105).
2. Submit a copy of the Plat of Survey showing the proposed location of the deck, the overall dimensions and the distances from the lot lines and other buildings on the property. Decks cannot be built on an easement.
3. **Submit a set of plans indicating framing sizes and spacing, post hole locations, and details on railings and stairs** (*IRC-R106).
4. If a contractor is used, they must be registered with the Village.

Specifications:

*Please note that these specifications are general and **not** comprehensive. Additional changes or suggestions may be made by the inspectors at the time of the site check in order to ensure that all construction is performed to code.*

1. Attached decks must meet the setback requirements for the applicable zoning district. **Exceptions:** Steps or ramps not over four feet (4') wide, by four feet (4') in depth, which are necessary for access to a permitted building or for access to a zoning lot from a street; unless existing ramps or stairs exceed four feet (4') in width, then a maximum of six feet (6') may be allowed (see Diagram 1). In rear yards only, open terraces and decks with railings which are a minimum of 50% open, not over four feet (4') above the average level of the adjoining ground but not including permanently roofed-over terrace or porch (*VC 11-4-3(E)(4)(e)).
2. Overhead electrical service lines must be ten feet (10') vertical from the deck floor and not within reach horizontally. A permit will not be issued until service line is first moved (*NEC-230.24).
3. Post holes must be a minimum of eight inches (8") in diameter and forty-two inches (42") deep. However, if a deck is over four feet (4') above grade, post holes must be a minimum of twelve inches (12") in diameter and posts must be a minimum of 6"x6" (*IRC-R403.1). All post holes shall have full size soni-tubes from top to bottom of hole. Posts are required to support each stair stringer. A pre pour inspection is required for all post holes (24 hour notice).
4. Galvanized post bases are required.
5. Decks over eighteen inches (18") high require railings; minimum railing height is thirty-six inches (36").
6. Stairs, with three or more risers, shall have handrails and guardrails to enclose the stairway. **No open stair risers are permitted.**
7. Railing posts shall be mounted inside of rim joists and blocked for stability.
8. Joist spans over eight feet (8') require bridging (*IRC-R502.7.1).
9. Weed blocking fabric covered with pea gravel is required under decks which are less than thirty-six inches (36") above grade.

*IRC – International Residential Code (2012)

*NEC – National Electrical Code (2011)

*VC – Village Code

Revised 03/2016

Inspections Required

The following inspections are required:

1. **Site Check** (before the permit can be issued an inspection to verify the location and plans meet the village codes.)
2. **Post Hole** (check the location, size and depth of the post holes.)
3. **Final Inspection** (verify the deck has been built in accordance with the approved plans.)

Sizing Lumber For A Deck

These charts will enable you to size beams, joists and decking boards for your deck. They will also tell you the maximum distances you can span with a board of a particular size. Span refers to the maximum distance a member can bridge between two supports. Spacing refers to the maximum distance a member can bridge between two supports. Spacing refers to the distance between identical members, such as joists or beams. The spans indicated are for typical, pine-treated lumber. Different species may require different spacing. Spans may be increased if designed by a licensed architect or structural engineer.

JOIST SPACING (Decking Span)

JOIST SPAN TABLE		
Joist Sizes	Distance Between Joists	
	16 inches	24 inches
2"x 6"	8 feet	7 feet
2"x 8"	11 feet	9 feet
2"x 10"	14 feet	12 feet
2"x 12"	17 feet	15 feet

BEAM SIZES Maximum allowable span between piers for wood support beams

2 – 2" x 6" on edge 5' - 6"

2- 2" x 8" on edge 7' - 6"

2- 2" x 10" on edge 9' - 6"

2- 2" x 12" on edge 11' - 0"

DECK REQUIREMENTS CHECKLIST
(Please submit with Permit Application)

To expedite the review and issuance of the building permit application for decks, please complete the following checklist. This checklist is for open, unenclosed decks only. If you desire to construct an enclosed or roofed deck, please consult with the Community Development Department for specific requirements.

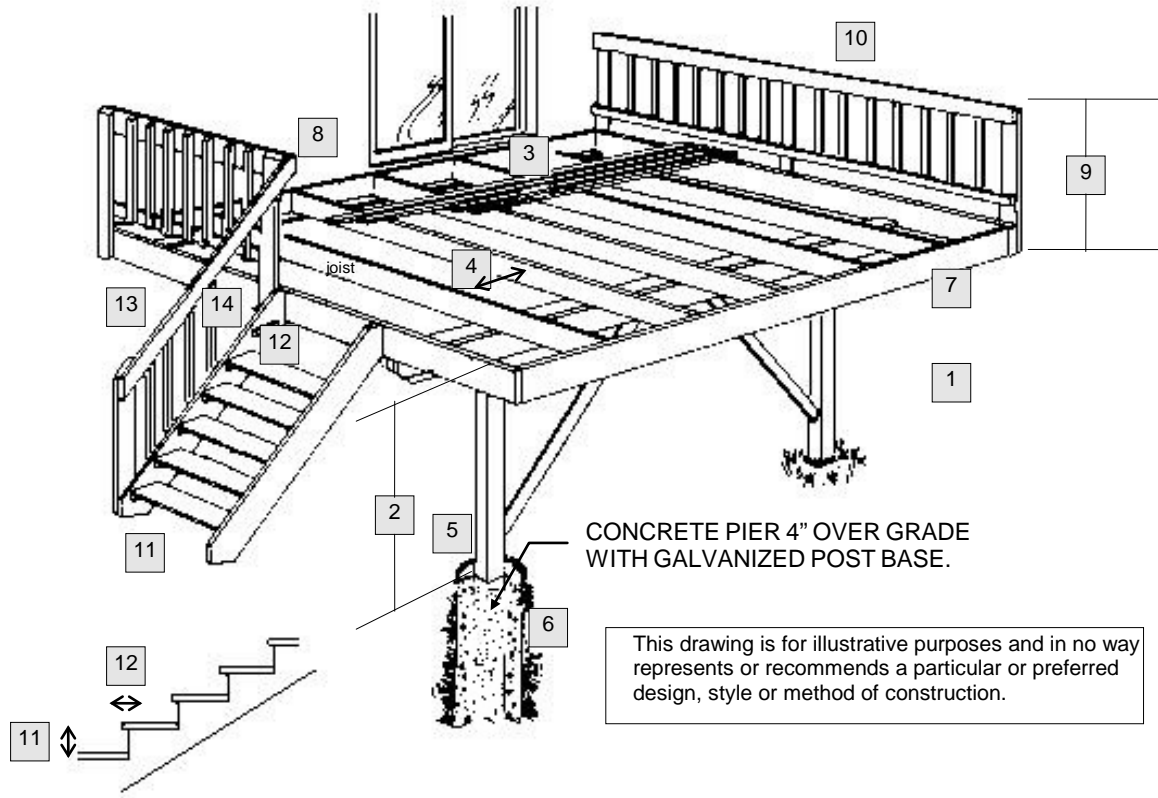

SIDE VIEW OF RISERS AND TREADS

1. THE DECK IS CONSTRUCTED OF WHAT TYPE OF MATERIAL? _____
(DECAY RESISTANCE WOOD IS REQUIRED IN ALL DECK CONSTRUCTION)
2. WHAT IS THE HEIGHT OF THE DECK FLOOR ABOVE THE GRADE OF THE YARD? _____ (INCHES)
3. WHAT IS THE THICKNESS OF THE DECK FLOOR? _____ (INCHES)
4. WHAT IS THE SIZE AND SPACING OF FLOOR JOISTS? _____" X _____" SPACED _____" (ON CENTER)
5. WHAT IS THE DEPTH, SIZE AND SPACING OF POSTS? _____" X _____", POST (6"X6" MIN. IF DECK OVER 4 FEET). POST IS LOCATED ON TOP OF PIER Y OR N, (MINIMUM PIER DEPTH 42" BELOW GRADE), AND SPACED _____' APART.
6. WHAT IS THE SIZE OF POST FOOTINGS? _____" DIAMETER. (8" MINIMUM DIAMETER; 12" MIN. IF DECK OVER 4 FEET).
7. WHAT ARE THE SIZE AND SPANS OF HEADER BEAMS? _____" X _____" X _____' LONG.

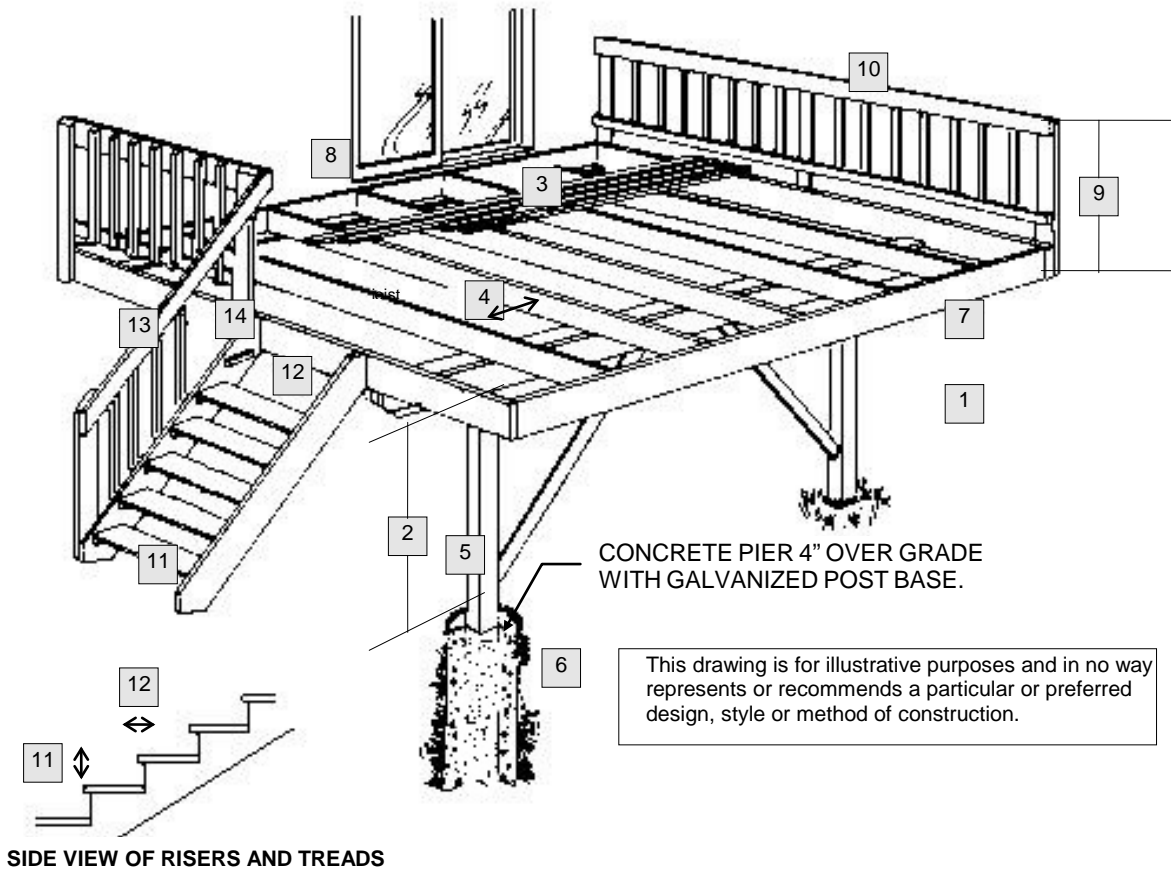

SIDE VIEW OF RISERS AND TREADS

8. IS THE DECK ATTACHED TO THE HOUSE? YES _____ NO _____ IF YES, WHAT TYPE OF FLASHING IS USED?

9. WHAT IS THE HEIGHT OF THE GUARDRAIL? _____" (GUARDRAIL IS REQUIRED IF DECK IS 18" OR MORE ABOVE GRADE; MINIMUM 36" HIGH)
10. ARE GUARDRAIL INTERMEDIATE ENCLOSURES: VERTICAL _____ OR HORIZONTAL _____? WHAT IS THE SPACING OF GUARDRAIL INTERMEDIATE ENCLOSURES? _____" (MAXIMUM CLEAR OPENING BETWEEN ENCLOSURES IS 4")
11. WHAT IS THE HEIGHT OF THE STAIR RISER? _____" (MAXIMUM 7¾")
12. WHAT IS THE WIDTH OF THE STAIR TREAD? _____" (MINIMUM 10")
13. IS A STAIR HANDRAIL PROVIDED? YES _____ NO _____ (HANDRAIL REQUIRED FOR 3 OR MORE STAIRS)
14. WHAT IS THE SPACING OF HAND RAIL INTERMEDIATE ENCLOSURES? _____" (MAXIMUM CLEAR OPENING BETWEEN ENCLOSURES IS 4" {*IRC-R312.1.3})

Signature/ Date

Figure 8. Post-to-Beam Attachment Requirements

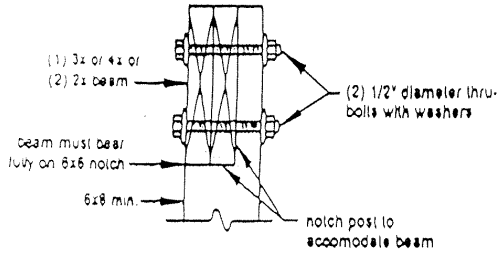
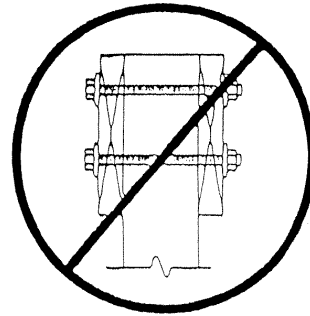

Figure 9. Prohibited Post-to-Beam Attachment Condition



DECK STABILITY

Decks greater than 4 feet above grade shall be provided with diagonal bracing

Figure 22. Diagonal Bracing Requirements

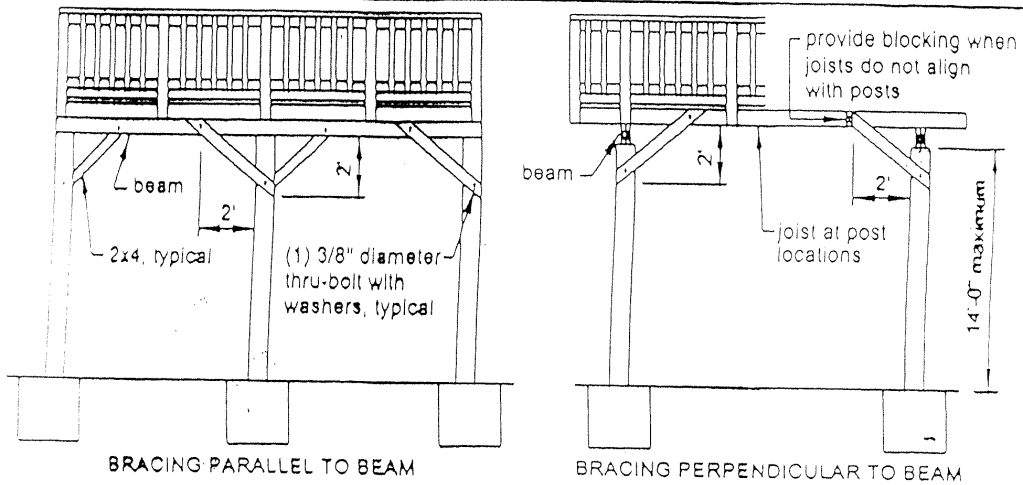

Required Setbacks and Lot Coverage

Please note that all decks must conform to all required setbacks, except for steps or ramps not over four feet (4') in depth by four feet (4') in width, which are necessary for access to a permitted building or for access to a zoning lot from a street, and lot coverage requirements. All detached accessory structures shall be located a minimum distance of five feet (5') from any other structures.

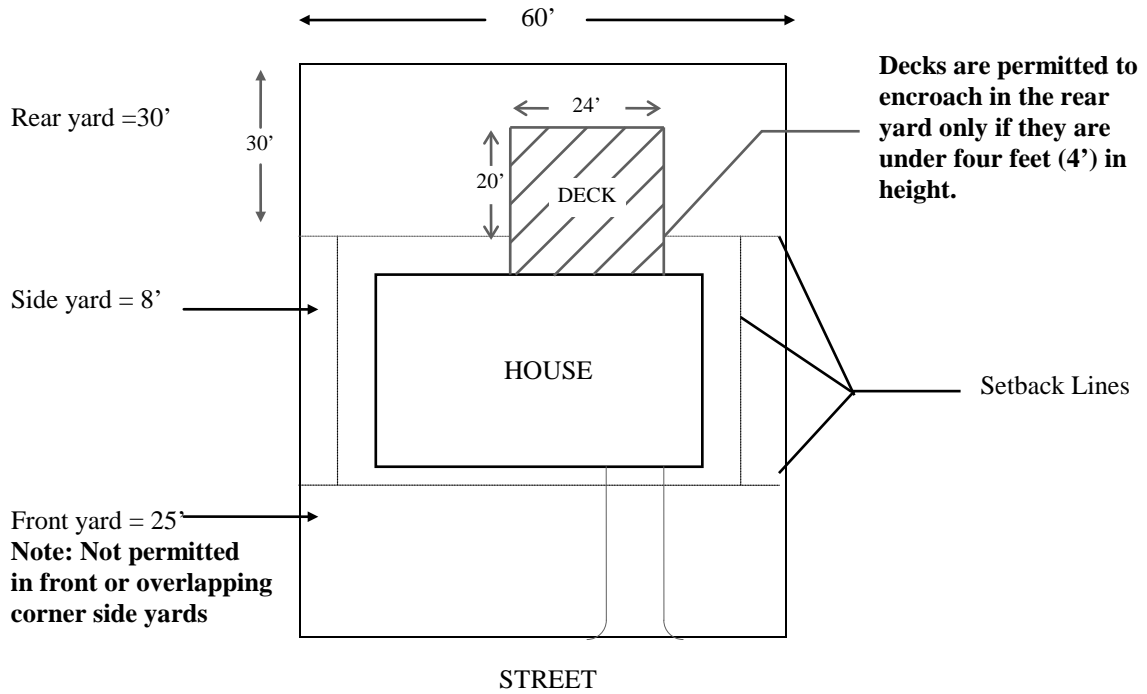

$$\frac{\text{Decked Area w/in Req. Yard}}{\text{Required Rear Yard Area}} = \frac{20' \times 24'}{60' \times 30'} = \frac{480 \text{ sf}}{1800 \text{ sf}} = 26.6\% \text{ (Max. 30\%)}$$

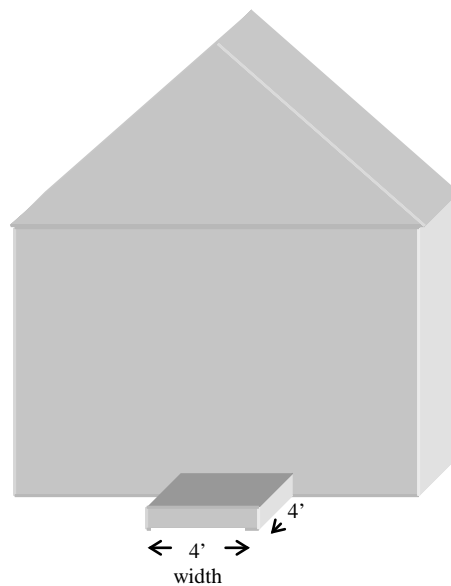

Diagram 1